

## *Installation Manual* **MULTI DISPLAY RD-30**

---

<b>SAFETY INSTRUCTIONS</b> .....	<b>i</b>
<b>SYSTEM CONFIGURATION</b> .....	<b>ii</b>
<b>EQUIPMENT LISTS</b> .....	<b>iii</b>
<b>1. INSTALLATION</b> .....	<b>1</b>
1.1 Installation of Display Unit.....	1
1.2 Wiring.....	3
<b>2. INITIAL SETTINGS</b> .....	<b>7</b>
2.1 Data Sentence Description .....	7
2.2 IEC 61162-1 (NMEA 0183) Input Data Sentences .....	8
2.3 Setting Input/Output .....	9
<b>PACKING LIST</b> .....	<b>A-1</b>
<b>OUTLINE DRAWINGS</b> .....	<b>D-1</b>
<b>INTERCONNECTION DIAGRAM</b> .....	<b>S-1</b>



**FURUNO ELECTRIC CO., LTD.**  
NISHINOMIYA, JAPAN

© **FURUNO ELECTRIC CO., LTD.**

9-52 Ashihara-cho,  
Nishinomiya, Japan

Telephone : 0798-65-2111

Telefax : 0798-65-4200

Your Local Agent/Dealer

All rights reserved.

Printed in Japan

PUB.No. IME-44130-E1

( YOSH ) RD-30

FIRST EDITION : MAR. 2001

E1 : FEB. 03,2003



\* 0 0 0 8 0 9 1 7 8 0 1 \*



\* I M E 4 4 1 3 0 E 1 \*



# SAFETY INSTRUCTIONS

## **WARNING**

**Do not open the cover unless totally familiar with electrical circuits and service manual.**

Improper handling can result in electrical shock.

**Turn off the power at the switchboard before beginning the installation.**

Fire or electrical shock can result if the power is left on.

**Be sure that the power supply is compatible with the voltage rating of the equipment.**

Connection of an incorrect power supply can cause fire or equipment damage. The voltage rating of the equipment appears on the label above the power connector.

## **CAUTION**



**Ground the equipment to prevent mutual interference.**

**Observe the following compass safe distances to prevent interference to a magnetic compass:**

	Standard	Steering
Display unit	0.35 m	0.25 m

# SYSTEM CONFIGURATION

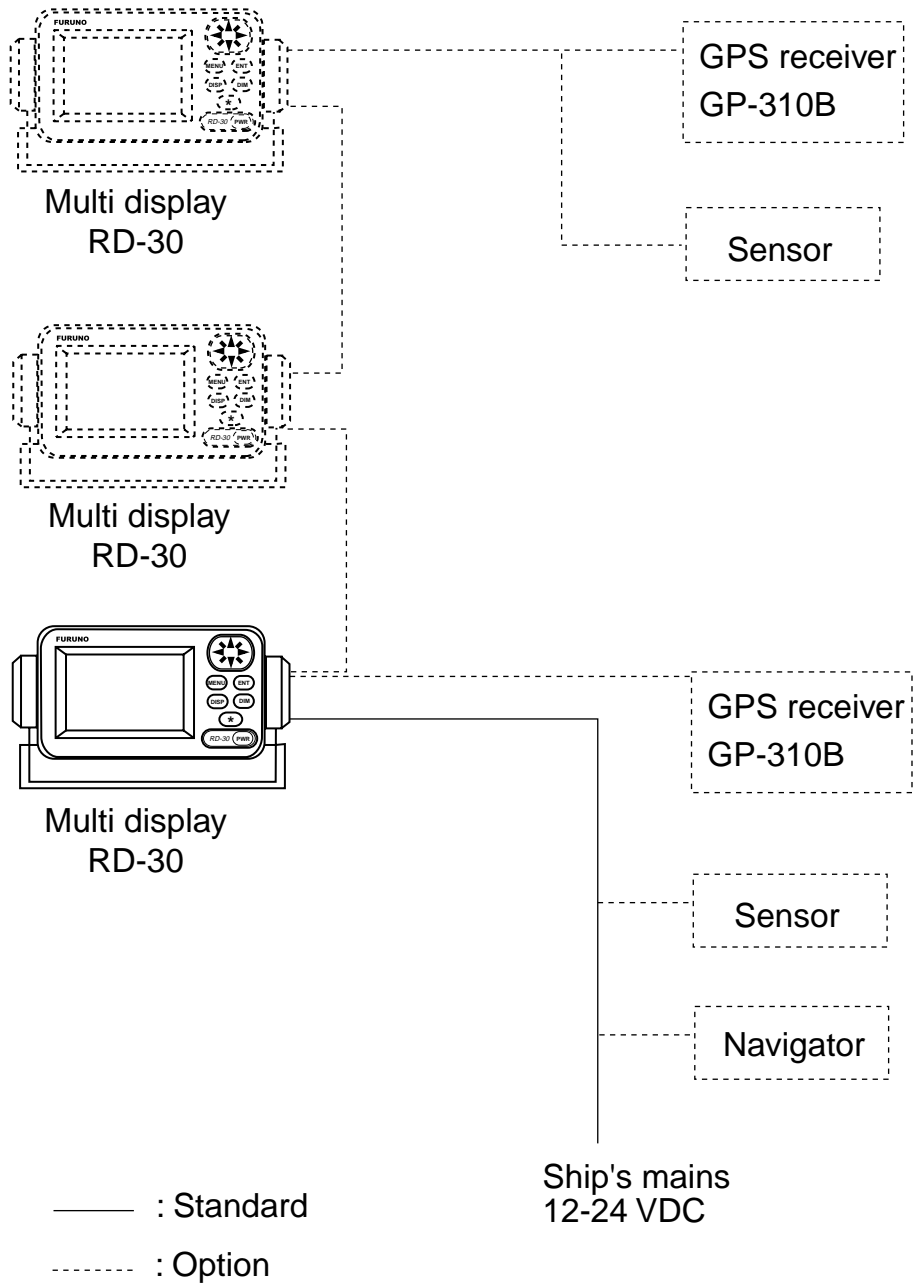

# EQUIPMENT LIST

## Standard supply

No.	Name	Type	Code No.	Qty	Remarks
1	Multi Display	RD-30	-	1	
2	Spare Parts	SP14-02901	-	1 set	
3	Installation Materials	CP14-06000	-	1 set	+Tapping screw (4 pcs) MJ-A7SPF0005-020
4	Accessories	FP14-02801	-	1 set	Hard cover

## Optional supply

No.	Name	Type	Code No.	Qty	Remarks
1	Flush Mount Kit S	OP20-17	000-040-720	1	For flush mounting the display unit
2	Flush Mount Kit F	OP20-29	000-041-405		
3	Cable Assy.	MJ-A7SPF0005-020	000-139-384	1	Power, signal
		MJ-A7SPF0006-100	000-143-578	1	7P-7P cross cable
		MJ-A7SPF/SRMD-100	000-144-534	1	7P-7P straight cable

## Sensors available

No.	Name	Type	Code No.	Qty	Remarks
1	Smart Sensor	235DT-MSE	000-144-981	1	Depth & Temperature Sensor
2	Smart Sensor	235DT-PSE	000-144-982	1	Depth & Temperature Sensor
3	Smart Sensor	235DST-PWE	000-144-983	1	Depth, Speed and Temperature Sensor
4	Smart Sensor	235DHT-LMSE	000-144-984	1	Depth and High Precision Temperature Sensor
5	Smart Sensor	235DHT-MSE	000-144-985	1	Depth and High Precision Temperature Sensor

For technical specifications see Airmar's technical data.

This page is intentionally left blank.

# 1. INSTALLATION

---

## 1.1 Installation of Display Unit

### Mounting considerations

The display unit can be installed on a tabletop, on the overhead, or in a panel (optional flush mounting kit required). Refer to the outline drawings at the end of this manual for installation instructions. When selecting a mounting location, keep in mind the following points:

- Locate the unit away from exhaust pipes and vents.
- The mounting location should be well ventilated.
- Mount the unit where shock and vibration are minimal.
- Locate the unit away from equipment which generates electromagnetic fields such as a motor or generator.
- Allow sufficient maintenance space at the sides and rear of the unit and leave sufficient slack in cables, to facilitate maintenance and servicing.
- Observe the following compass safe distances to prevent deviation of a magnetic compass.

Standard compass, 0.35 m, Steering compass, 0.25 m.

### Tabletop and overhead mounting

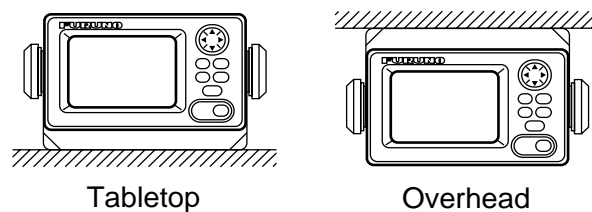

*Figure 1-1 Tabletop and overhead mounting methods*

## Flush mounting

There are two types of flush mount kits, F type and S type. For details, see the outline drawings at the back of this manual.

### F type

Flush mount kit F (Type: OP20-29, Code No.: 000-041-405)

No.	Name	Type	Code No.	Qty	Remarks
1	Cosmetic Panel	20-016-1051	100-251-370	1	
2	+ Tapping Screw	5x20 SUS304	000-802-840	4	
3	Hex Bolt	M6x12 SUS304	000-862-127	2	
4	Spring Washer	M6 SUS304	000-864-260	2	

1. Make a cutout of 183 X 92 mm.
2. Attach the cosmetic panel (supplied) to the display unit with hex bolts (M6X12, supplied) and spring washers (M6, supplied).
3. Fix the display unit to the mounting location with four tapping screws (5X20, supplied).

### S type

Flush mount kit S (Type: OP20-17, Code No.: 000-040-720)

No.	Name	Type	Code No.	Qty	Remarks
1	Fixing Metal	20-007-2401	100-183-190	2	
2	Wing Bolt	M4x30 YBSC2 MBN12	000-804-799	4	
3	Hex Bolt	M6x12 SUS304	000-862-127	2	
4	Wing Nut	M4 YBSC2 MBN12	000-863-306	4	
5	Spring Washer	M6 SUS304	000-864-260	2	

1. Make a cutout of 167 X 92 mm.
2. Attach two fixing metals (supplied) to the display unit with hex bolts (M6X12, supplied) and spring washers (M6, supplied).
3. Screw four wing bolts (supplied) into wing nuts (supplied).
4. Fasten the display unit to the mounting location with four sets of wing bolts and nuts assembled at step 3.

## 1.2 Wiring

The figure below shows where to connect cables on the rear of the display unit.

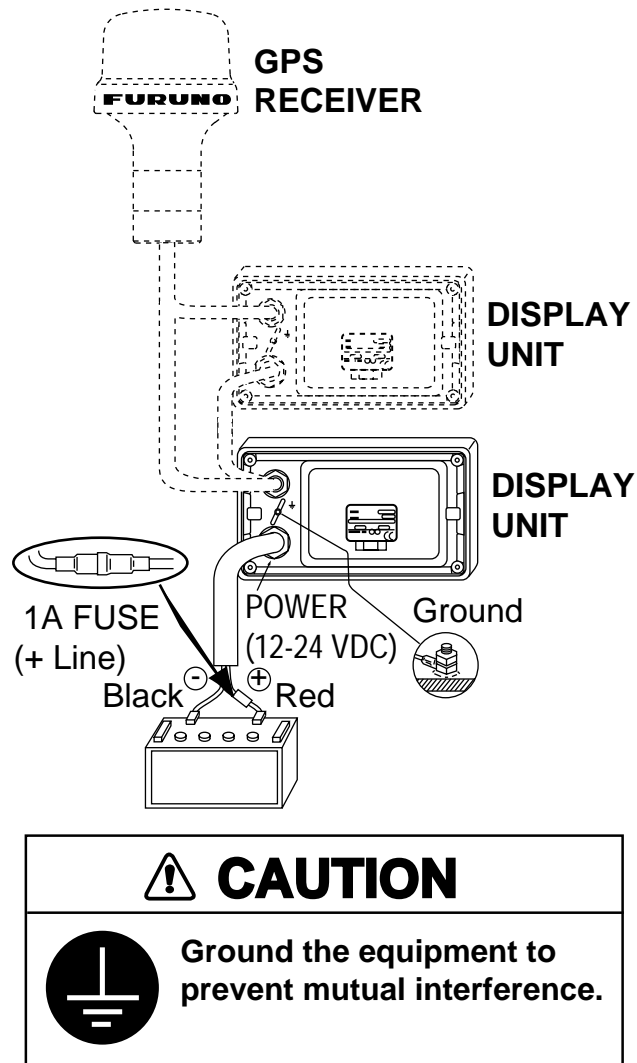

Figure 1-2 Wiring

**Note:** The fuse holder contains a spring which fixes the fuse. To prevent detachment of the spring, which would cause loss of power, tie the line as shown in Figure 1-3.

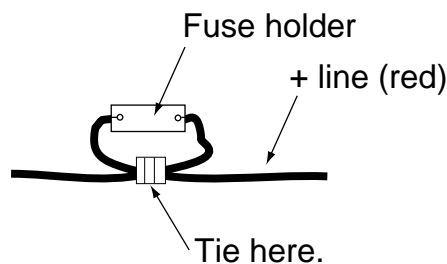

Figure 1-3 How to fix spring in fuse holder

## Grounding

The display unit contains a CPU. While it is operating, it radiates noise, which can interfere with radio equipment. Ground the unit as follows to prevent interference:

- The ground wire should be 1.25 sq or larger.
- The ground wire should be as short as possible.
- The signal ground and frame ground are separated, however the power line is not isolated. Therefore, do not connect the signal ground to the frame ground when connecting other equipment to a positive ground battery.

## External equipment

The power supply port (IN/OUT port) is commonly used for connection of external equipment such as navigation equipment or a PC. Refer to the interconnection diagram on page S-1 for connection.

### *IN/OUT port*

Connector		Remarks
1	TD-A	IEC61162-1/NMEA 0183
2	TD-B	
3	RD-H	IEC61162-1/NMEA 0183
4	RD-C	
5	+V	Power supply (12-24VDC) (INPUT)
6	GND	
7	FG	

### *AUX port*

Connector		Remarks
1	TD-A	IEC61162-1/NMEA 0183
2	TD-B	
3	RD-H	IEC61162-1/NMEA 0183
4	RD-C	
5	+Vout	Max 300 mA (OUTPUT)
6	GND	
7	FG	

## One Display Unit

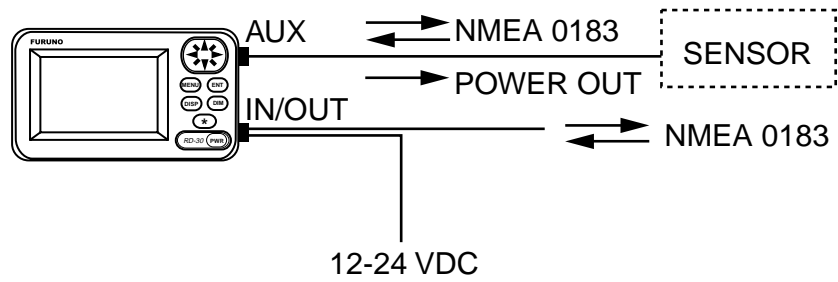

## Two Display Units

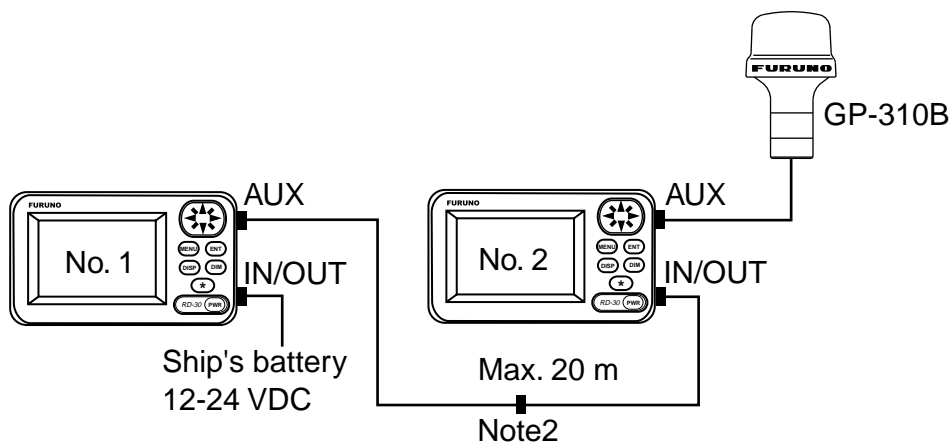

## Three Display Units

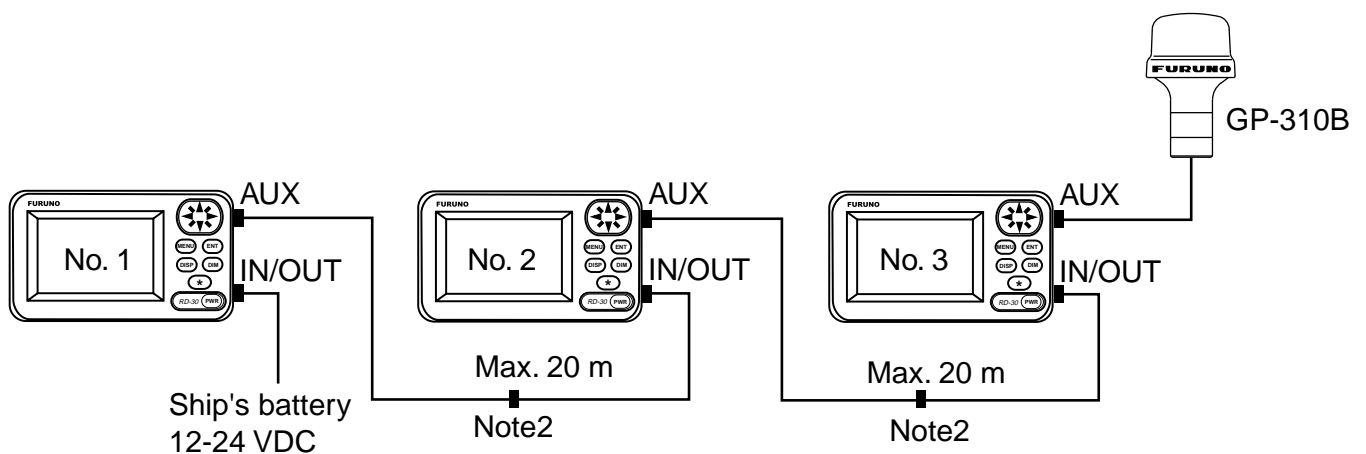

**Note1:** A set of one GP-310B and three RD-30 can be powered with 12-24 VDC power.

**Note2:** For cable length up to 10 m use cable type MJ-A7SPF0006-100 (cross cable), and for cable length 10-20 m use cable type MJ-A7SPF0006-100 (cross cable) and MJ-A7SPF/SRMD-100 (straight cable). Maximum length between the units is 20 m.

**Note3:** Turn on display units in sequential order.

**Note4:** Refer to the following table to connect a sensor other than the GP-310B. Do not exceed the maximum output current and the output voltage range.

Ship's Battery	One RD-30		Two RD-30		Three RD-30	
	Maximum output current	Output voltage range	Maximum output current	Output voltage range	Maximum output current	Output voltage range
12 VDC	300 mA	10.0-14.9 V	180 mA	9.2-14.4 V	60 mA	8.7-14.1 V
24 VDC	300 mA	21.0-30.5 V	180 mA	20.4-30.2 V	60 mA	20.4-30.3V

For example, in the three display units connection, a sensor with maximum current 60 mA and input voltage range 8.7-14.1 V or 20.4-30.3 V can be connected.

## 2. INITIAL SETTINGS

---

This equipment can input and output navigation data to external equipment in IEC 61162-1 (NMEA 0183) format. Input data is output as raw data. For output setting, refer to the operator's manual of the equipment.

### 2.1 Data Sentence Description

APB: Autopilot sentence data  
BWC: Range and bearing to waypoint (great circle navigation)  
BWR: Range and bearing to waypoint (rhumb line)  
COG: Course over ground  
DBK: Depth  
DBS: Depth  
DBT: Depth below transducer  
DPT: Depth  
GGA: GPS position fixing condition (time of fix, latitude, longitude, receiving condition, number of satellites used, DOP)  
GLC: Geographic position Loran-C  
GLL: Latitude and longitude  
GTD: Loran-C time difference  
HDG: Heading, deviation and variation  
HDM: Heading, magnetic north  
HDT: Heading true  
MDA: Wind direction and speed  
MTW: Water temperature  
MWV: Wind direction and speed  
RMB: Generic navigational information (cross track error, steering direction, starting waypoint no., destination waypoint no., latitude and longitude of starting waypoint, latitude and longitude of destination waypoint, range and bearing to waypoint, range and bearing from present position to destination waypoint, velocity to destination, arrival alarm)  
RMC: Generic navigational information (UTC time, latitude, longitude, ground speed, true course, day, month, year)  
ROT: Rate of Turn  
VBW: Water speed and ground speeds  
VDR: Tidal current direction and current speed  
VHW: Water speed and heading  
VTG: Actual track and ground speeds  
VWR: Relative wind direction and speed  
VWT: Actual wind direction and speed  
XTE: Course error amount and direction to steer  
ZDA: UTC time (day, month, year)

## 2.2 IEC 61162-1 (NMEA 0183) Input Data Sentences

The AUX port has priority when the same data sentences are input at it and the IN/OUT port simultaneously.

> = Priority order

Position:	GGA>RMC>GLL
Time:	ZDA>GGA
Speed over ground:	VTG>RMC>VBW
Speed through water:	VHW>VBW
Wind speed, direction:	True: MWV(T)>VWT>MDA Apparent: MWV(R)>VWR
Water temperature:	MTW>MDA
Depth:	DPT>DBT >DBS >DBK
Course:	VTG>RMC
Heading:	HDT>HDG>HDM>VHW
Waypoint:	RMB>BWR>BWC
Current set and drift:	VDR
Atmospheric pressure:	MDA (Bar>Inch, converted to hPa)
Humidity:	MDA (True>Relative)
Cross-track error:	XTE>APB>RMB
Time difference:	GLC>GTD
Temperature:	MDA
Rate of Turn:	ROT

## 2.3 Setting Input/Output

The I/O SETUP menu sets up the IN/OUT and AUX ports on the RD-30. Additionally you can use this menu to output power to other display units, in case of multiple display units.

**Note:** Note that the equipment can process data input at the rate of up to 430 characters/second. Some delay will occur when processing data input at a higher rate.

1. Press the [MENU] key once or twice to open the main menu.
2. Select I/O SETUP and then press the [ENT] key.

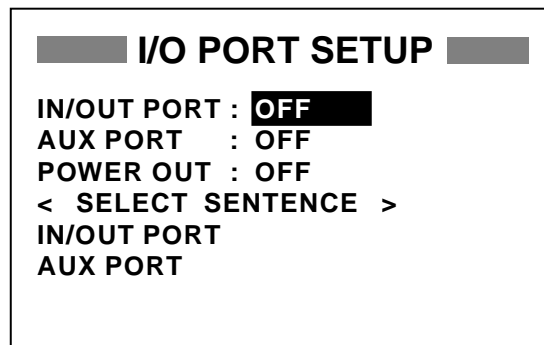

*Figure 2-1 I/O PORT SETUP menu*

3. Select IN/OUT PORT, AUX PORT or POWER OUT as appropriate and then press the [ENT] key. One of the following displays appears depending on your selection.

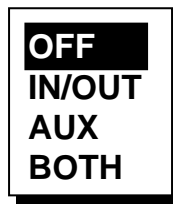

IN/OUT and  
AUX options



POWER OUT  
options

**OFF:** No output

**ON:** Outputs power to other display units

**OFF:** No output

**IN/OUT:** Output data which is input through the IN/OUT port.

**AUX:** Output data which is input through the AUX port.

**BOTH:** Output mixed data which is input through the IN/OUT and AUX ports.

*Figure 2-2 IN/OUT PORT, AUX PORT and POWER OUT options*

**Note:** If, when BOTH is selected, the data sentence which has an input interval faster than one second (ROT, HDT, etc.) is turned on, some data may not be output.

4. Select appropriate option and then press the [ENT] key.
5. When OFF, IN/OUT or AUX is selected for the IN/OUT or AUX port, go to step 8.  
When "BOTH" is selected for IN/OUT or AUX port, select IN/OUT PORT or AUX PORT of the SELECT SENTENCE and then press the [ENT] key.

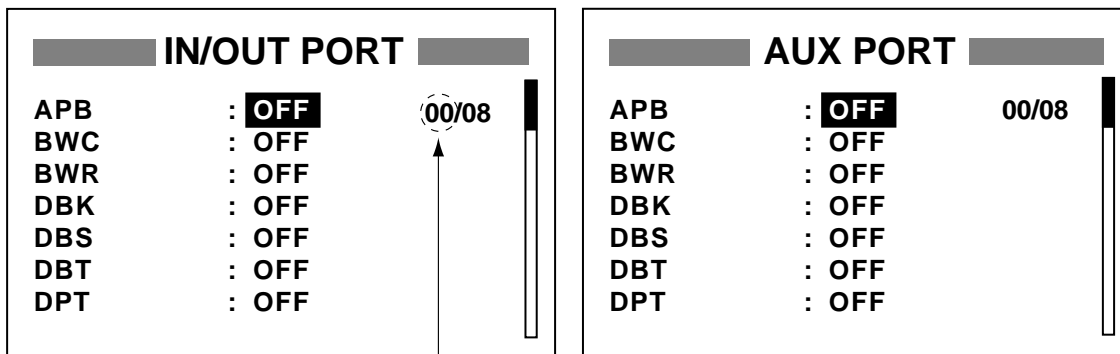

Number of sentences  
currently turned on

*Figure 2-3 IN/OUT PORT and AUX PORT menu*

**Note:** Sentences currently being received are shown in reverse video.

6. Select sentence to output and then press the [ENT] key. Use ▼ or ▲ to scroll the display.



*Figure 2-4 IN/OUT PORT and AUX PORT options*

7. Select ON or OFF as appropriate and then press the [ENT] key. You can turn ON up to eight sentences.
8. Press the [MENU] key twice to close the menu.

See the next page for examples of port settings.

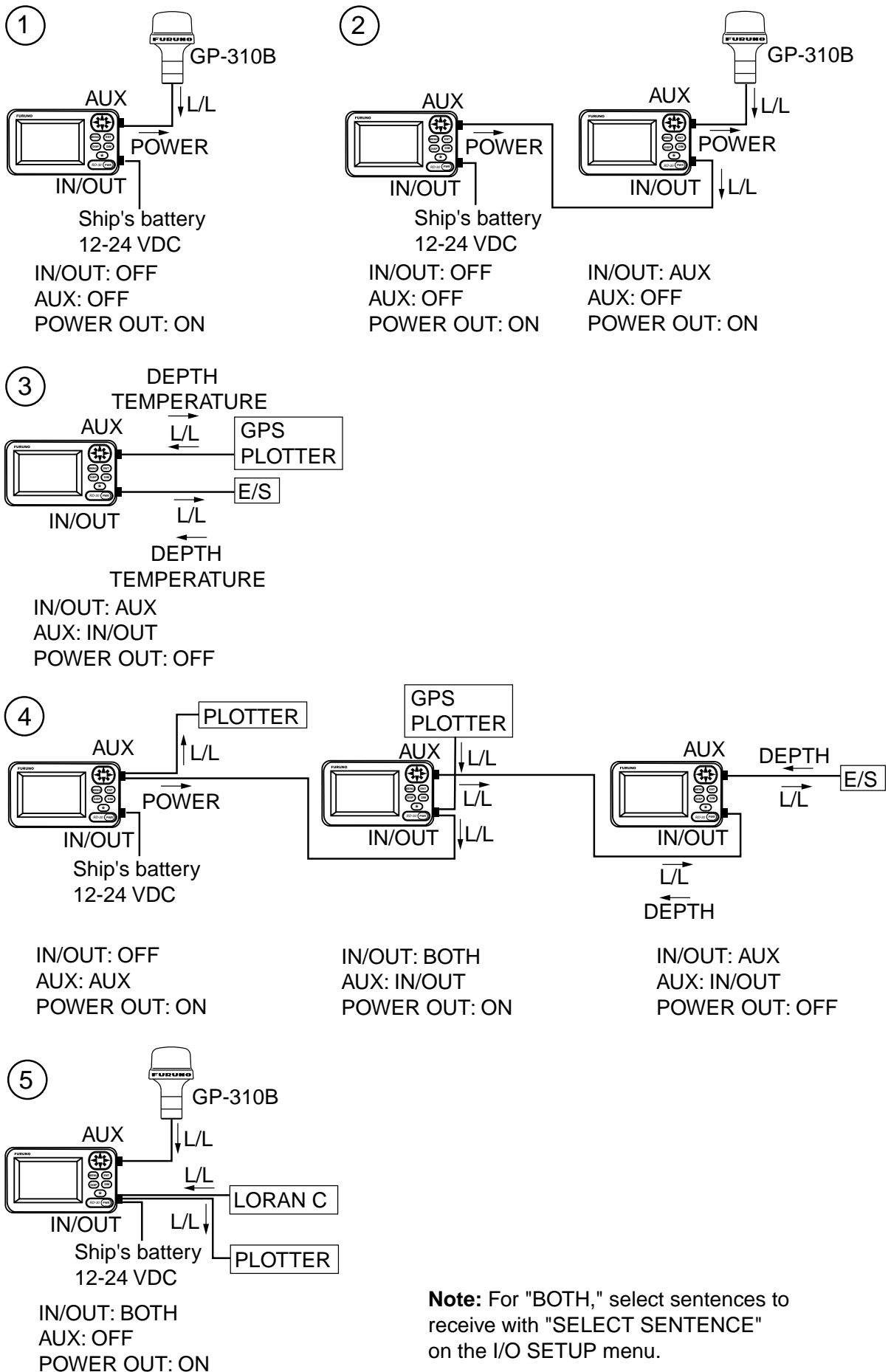
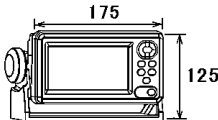
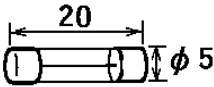
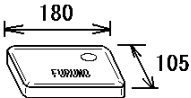
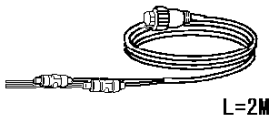
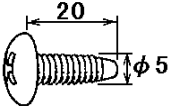

Figure 2-5 Example of I/O PORT SETUP

## PACKING LIST

14CJ-X-9851 -4 1/1

RD-30

NAME	OUTLINE	DESCRIPTION/CODE No.	Q'TY
<b>ユニット</b> UNIT			
マルチディスプレイ MULTIDISPLAY		RD-30-E 000-041-574 **	1
<b>予備品</b> SPARE PARTS		<b>SP14-02901</b>	
ヒューズ FUSE		FGMB 1A 125V 000-114-805	2
<b>付属品</b> ACCESSORIES		<b>FP14-02801</b>	
保護カバー COVER		20-016-1091-2 100-297-032	1
<b>工事材料</b> INSTALLATION MATERIALS		<b>CP14-06000</b>	
ケーブル組品MJ CABLE ASSY.		MJ-A7SPF0009-020 000-145-612	1
+トラスタップネジ +TAPPING SCREW		5X20 SUS304 1ヶ 000-802-081	4

3.コード番号末尾の[\*\*]は、選択部品の代表コード番号を表します。

CODE NUMBER ENDED BY "\*\*" INDICATES THE NUMBER OF TYPICAL MATERIAL.

(略図の寸法は、参考値です。 DIMENSIONS IN DRAWING FOR REFERENCE ONLY.)

3 4

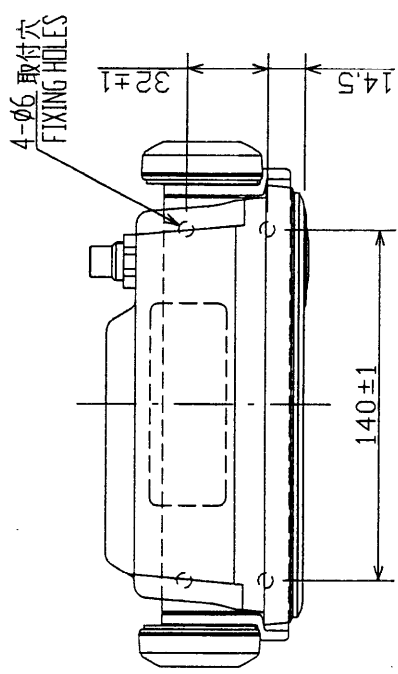

寸法区分 (mm) DIMENSION	公差 (mm) TOLERANCE
0 < L ≤ 50	±1.5
50 < L ≤ 100	±2.5
100 < L ≤ 500	±3

表 1  
TABLE 1

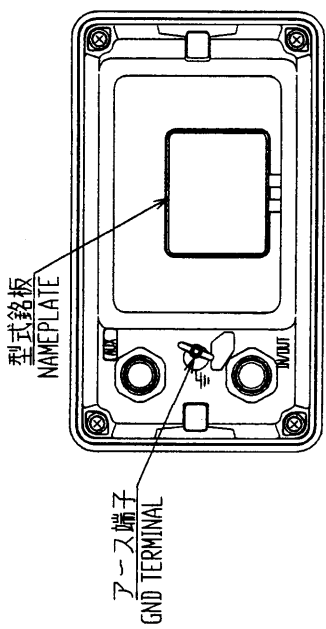

矢視 A  
VIEW A

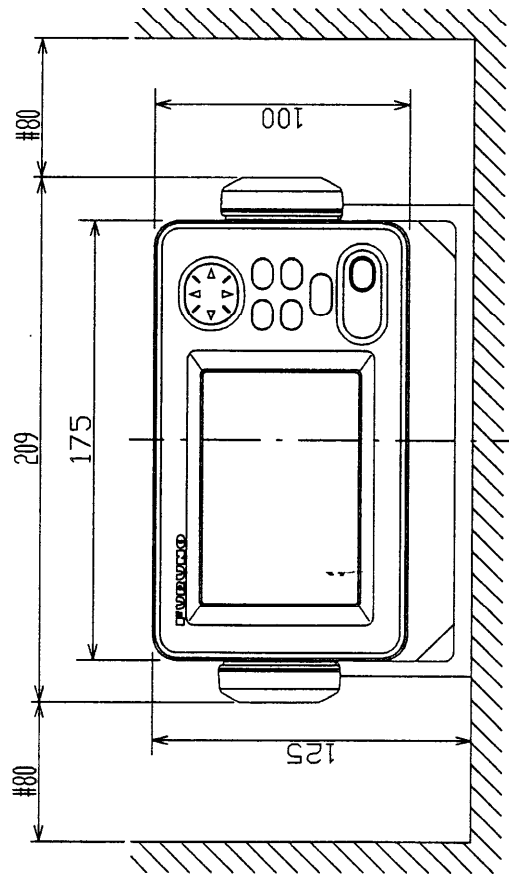
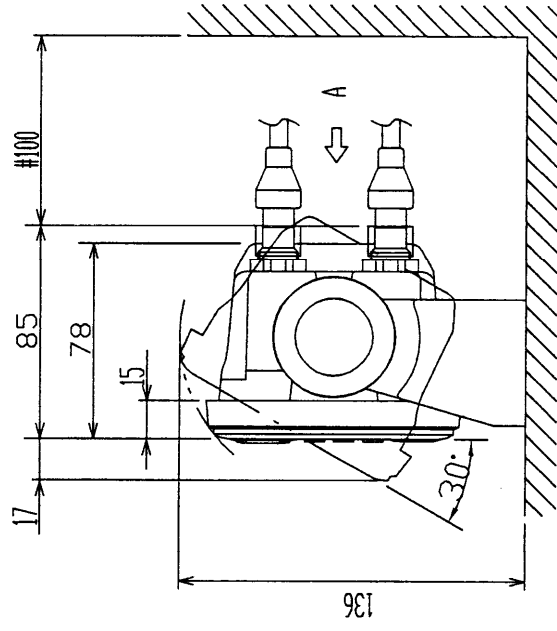

注 記

- 1) # 印寸法は最小サービス空間寸法とする。
- 2) 指定外の寸法公差は表 1 による。
- 3) 取付用ネジはトラスタップピンネジ呼び径 5×20 を使用のこと。
- 4) 接続ケーブルはサービス時、本体を前方に十分引き出せるよう余裕を持たせること。

NOTE

1. # RECOMMENDED SERVICE CLEARANCE.
2. TABLE 1 INDICATES TOLERANCE OF DIMENSIONS.
3. USE TAPPING SCREWS 5x20 FOR FIXING UNIT.
4. KEEP SUFFICIENT CABLE LENGTH BEHIND UNIT.

DRAWN	APPROVED	CHECKED	DATE	SCALE	WORKS	DESIGN NO.	MODEL	TITLE
1/3	1/3	1/3	12.12.78	1/3	Y. KAKI	C4413-501-B	RD-30	マルチディスプレイ

14-071-100G-1  
OUTLINE DRAWING

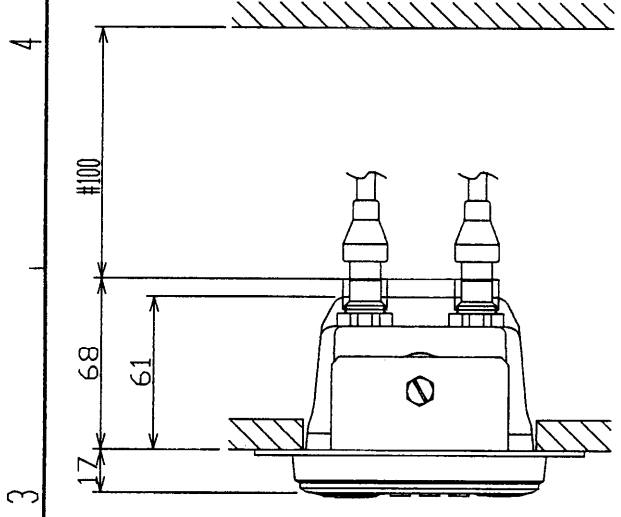

寸法区分 (mm) DIMENSION	公差 (mm) TOLERANCE
0 < L ≤ 50	±1.5
50 < L ≤ 100	±2.5
100 < L ≤ 500	±3

表 1  
TABLE 1

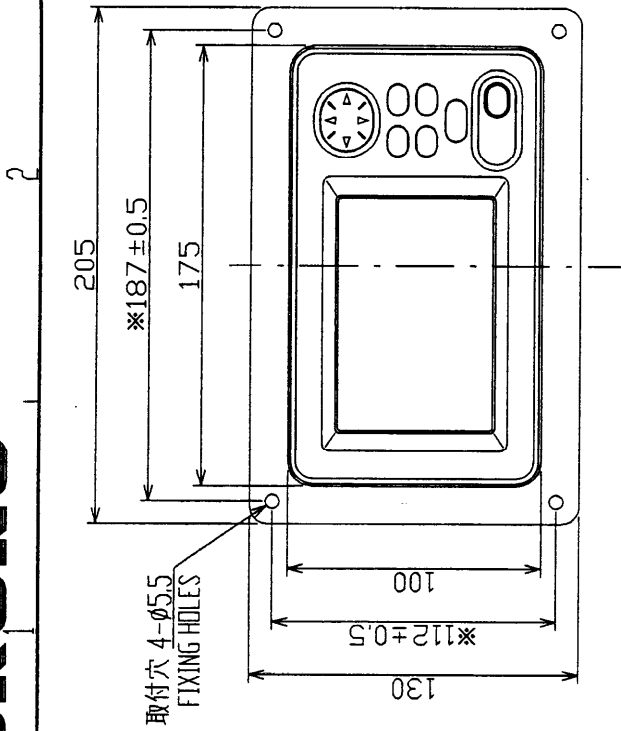

取付穴 4-φ5.5  
FIXING HOLES

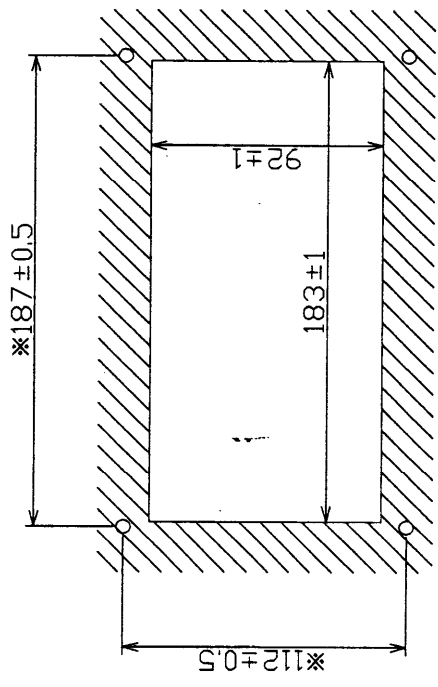

取付穴寸法図 (参考図)  
CUTOUT DIMENSIONS

注 記

- 1) #印寸法は最小サービス空間寸法とする。
- 2) 指定外の寸法公差は表1による。
- 3) 取付用ネジはタッピンネジ呼び径5×20を使用のこと。
- 4) ※印寸法は取付穴位置寸法とする。

NOTE

1. # RECOMMENDED SERVICE CLEARANCE.
2. TABLE 1 INDICATES TOLERANCE OF DIMENSIONS.
3. USE TAPPING SCREWS 5×20 FOR FIXING UNIT.
4. \* DIMENSION OF FIXING HOLES PITCH.

DRAWN APP. 12.02 CHECKED A. MATSUDA, K. KAWA APPROVED S. ITO SCALE 1/3	DESIGNER I. YAMASAKI	TITLE RD-30
NAME MULTI-DISPLAY (埋込装備 F)	MODEL MULTI-DISPLAY (FLUSH MOUNT F)	OUTLINE DRAWING
DATE 14-071-110G-1		

3 4

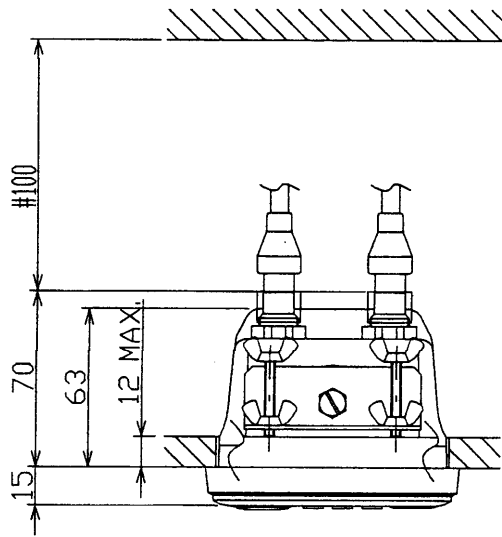
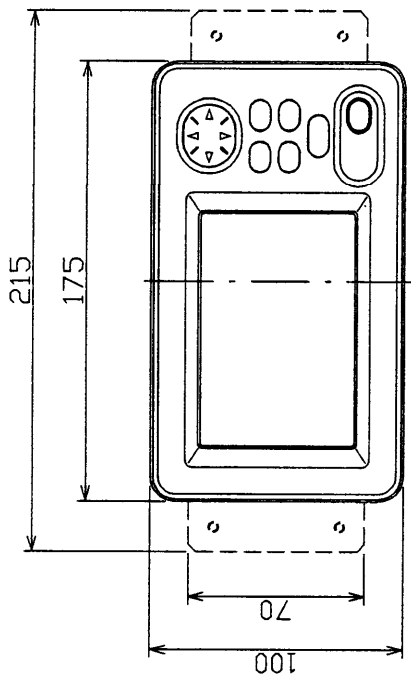

寸法区分 (mm) DIMENSION	公差 (mm) TOLERANCE
0 < L ≤ 50	±1.5
50 < L ≤ 100	±2.5
100 < L ≤ 500	±3

表 1  
TABLE 1

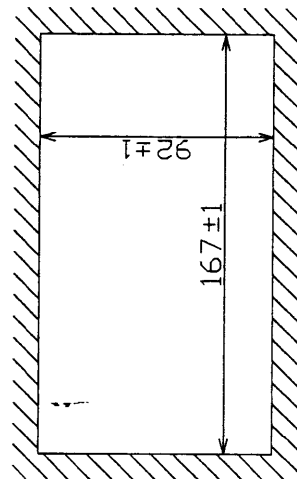

取付穴寸法図 (参考図)  
CUTTING DIMENSIONS

- 注 記
- 1) 寸法は最小サービス空間寸法とする。
  - 2) 指定外の寸法公差は表 1 による。
- NOTE
1. # RECOMMENDED SERVICE CLEARANCE.
  2. TABLE 1 INDICATES TOLERANCE OF DIMENSIONS.

DRAWN	RD-30	TITLE	RD-30
CHECKED	LYAMASAKI	名称	マルチディスプレイ (埋込装置 S)
APPROVED		外寸図	
SCALE	1/3	WAVE	MULTI-DISPLAY (FLUSH MOUNT S)
DATE	14-07-1206-1	FIGURE	OUTLINE DRAWING

A

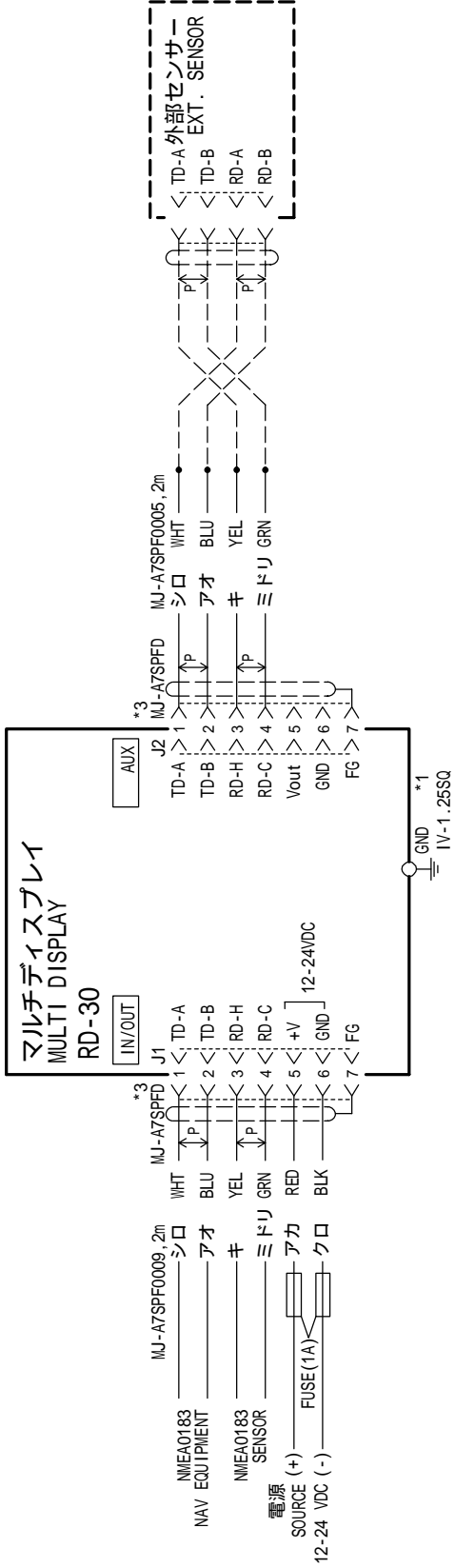

B

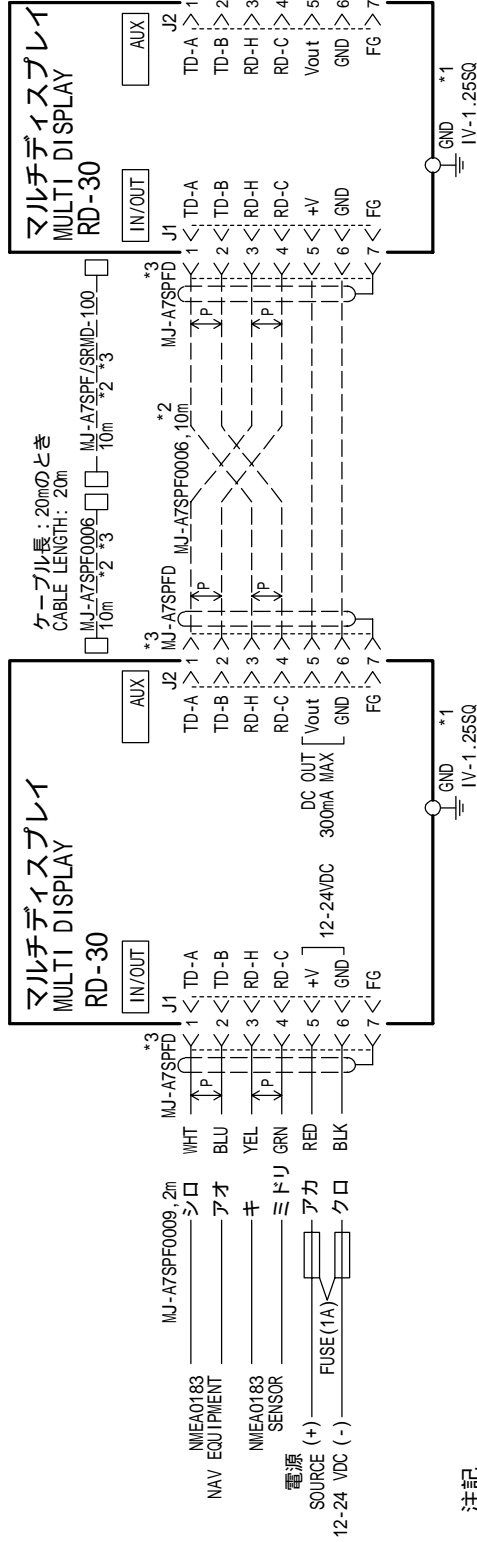

C

注記

- \* 1 ) 造船所手配。
- \* 2 ) オプション。
- \* 3 ) コネクタは工場にて取付済み。

NOTE

- \* 1. SHIPYARD SUPPLY.
- \* 2. OPTION.
- \* 3. FITTED AT FACTORY.

DRAWN	Jan. 31 '03	T. YAMASAKI	TITLE	RD-30
CHECKED	Jan. 31 '03	Y. KIMURA	名称	マルチディスプレイ
APPROVED	Jan. 31 '03	Y. Kimura	相互結線図	
SCALE		MASS kg	NAME	MULTI DISPLAY
DWG. No.		C4413-C01-C	INTERCONNECTION DIAGRAM	